

# Voice Controlled Robotic Surveillance With Live Video Streaming

L.Sathish Kumar

Asst. Prof, Dept. Of ECE, SCSVMV University, India

**Abstract:** Today Robots play a major role in Defense area for surveillance. Here in this paper we propose a Robot built with live video streaming as with vision, temperature and humidity recording in addition with earth quake detection. The technology is based on Human-Robot Interaction (HRI).

**Keywords:** Mobile Robot, Human-Robot Interaction, Remote Control, Robot Vision, Sensing Elements.

## I. INTRODUCTION

This paper represents an intelligent robot which is used for monitoring the environment and extracting information in the environment. This robot will extract sensing details and climatic conditions. The robots are designing with advancement of embedded systems and this wireless technology. These robots are used in indoor and outdoor based on SLAM applications [1]. This type of robots are very useful in military applications. Depending on the application robots are designed in various fields. The robot intended in this paper is used for the military surveillance and monitoring the environment. This mobile robot are designed according to the environment and place. This type of robots are designed in such a way that these are compatible to the environment. The mobile are designed in various models and designs according to the monitoring area. this robot are designed in such a way that these are suitable to the environment according there construction and design and driver mechanism. The robots are widely used in military applications and in future it will helpful to military application. Some of the robots are already in existing state Examples are the space exploratory robot [2], urban search and rescue robot [3], bomb disposal robot [4] and subsea service robot [5] . these are some of the examples.

## II. MAIN COMPONENTS

### 1. Mobile Robot

The mobile robot is designed based on the Atmel micro controller board. This play major role which connects all the components and gains the data from them. Mobile robot comprises of the driver mechanism which drives the DC motor which robot to move

### 2. DC motor:

A DC motor is designed to run on DC electric power. Two examples of pure DC designs are Michael Faraday's homo polar motor (which is uncommon), and the ball bearing motor, which is (so far) a novelty. By far the most common DC motor types are the brushed and brushless types, which use internal and external commutation respectively to create an oscillating AC current from the DC source—so they are not purely DC machines in a strict sense.

We in our project are using brushed DC Motor, which will operate in the ratings of 12v DC 0.6A which will drive the flywheels in order to make the robot move.

## III. DRIVER CIRCUIT

In this we are using the driver circuit based on the monolithic TTL logic. The ULN2003 is a monolithic high voltage and high current Darlington transistor arrays. It consists of seven NPN Darlington pairs that feature high-voltage outputs with common-cathode clamp diode for switching inductive loads. The collector-current rating of a single Darlington pair is 500mA. The Darlington pairs may be paralleled for higher current capability. Applications include relay drivers, hammer drivers, lamp drivers, display drivers (LED gas discharge), line drivers, and logic buffers. The ULN2003 has a 2.7kW series base resistor for each Darlington pair for operation directly with TTL or 5V CMOS devices. By using the above we are performing driver operation for the mobile robot and its mechanism is controlled by the driver circuit.

### 3. Human Robot Interaction:

Normally robots are designed in such a way that they should be interacted with human so this interaction is meant for monitoring. This (HRI) is mainly intended to perform tasks and access robot remotely and maintain them this interaction is mainly meant on the basis of the HRI stastics which will be mentioned below.

HRI describes the relationship and interaction between the robot and the human. HRI another area as robots need to be more adaptable due to the dynamic robotic environment which includes varying parameters such as other objects, lighting, noise and signals. Concept in HRI started with the tele-operation in factories [6].

Besides engineering, HRI also involves cross disciplinary area in psychology, sociology and cognitive science to enhance the human experience during HRI.

A structural relationship should be determined to manage information flow between human and the robot for decision making in their shared objectives. Human users can span a large spectrum of variability in HRI.

Modalities for HRI Human has five natural senses namely the vision, audio, tactile, smell and taste. Modalities for human to communicate with the robot can be varying through various combinations of vision, audio or tactile senses. These are a subset of human senses that can help human to build relationship with the robot.

Tactile sensor is the most straightforward by using wired or wireless means to command or maneuver the robot. This communication medium requires an operational device or equipment between the robot and human.

This modality is essential, especially for occupational robot, when the robot must carry out specific task. Other than that, emergency stop or system reboot button is a necessity for all robots.

Vision and audio sensors lean towards the natural form of HRI modality.

When robot is close proximity to human, it should have some natural means of communication to create certain degree of comfort to human during the interaction process. Robot with natural communication capability can attract human attention and reduce the frustration of having to use an external device to interact with each other.

Through audio sensory system, human communicates with robot through speech understanding [7]. By using vision sensor, a robot is able to acknowledge human presence [8] and understands human needs through gestures [9].

These natural modalities are desirable features in service and companion robots due to the closely shared environment with human. At the same time, the robot should be able to convey message or signal back to human to achieve a two-way communication.

Most robot exhibits the feedback of human command through its behavior. The information returned can come in the form of parametric data, sound or image. Information can be perceived through direct observation or from the remote control center.

Classification in HRI Design Similar to design of the robot's physical structure and locomotion method, the HRI design should also be application specific.

A common protocol in HRI is needed to enhance the operability between the agents involved. The agents can consist of one or more human and robot.

Scholtz [10] gave a summary of user-centric design in development of HRI. They are generalized into seven steps which are formulation of goal, formulation of intention, specification of intention, execution of action, perception of system state, interpretation of system state and evaluation of outcome.

HRI design can be classified into various segments subjected to human and robot localization, interaction mode and human view of the robot [11].

|                  |              |  |
|------------------|--------------|--|
| Location         | Immediate    | Human and robot are in situated in the same environment. Both have direct contact with each other.   |
|                  | Intermediate | Human is not far away from robot but requires external equipment to interact with robot.   |
|                  | Remote       | Robot is far away from human and its operating environment is unknown to the human. There is tendency for communication breakdown. External equipment is required for interaction. |
| Interaction      | Passive      | Robot goes about doing its pre-programmed task without human constant need of observation or intervention.   |
|                  | Semi-active  | Human learns from robot about its environment. Robot does not learn from human during operation but performs the pre-programmed tasks.   |
|                  | Fully-active | Human and robot learns from each other on site.  |
| Human experience | Human        | Human is present in the robotic environment. Human sees the world that contains the robot and its operating environment through his/her own eyes                                   |
|                  | Robot        | Human sees the robotic environment through the robot's vision  |
|                  | Third-party  | Human sees the robot and its operating environment through the eyes of another observer. For instance, a camera mounted on the wall.   |

Vision Capability for HRI in Mobile Robots Among the five human natural senses, vision is the most essential for human to experience the robot. Vision sensor can be employed for natural HRI and for human to observe and control the robot from various locations. However, employment of vision capability into mobile robots is not a trivial task for vision-based recognition or image/video transmission. Vision-based object recognition can be computationally complex due to the variances in the environment such as the illumination, background and presence of other objects. Other factors can be due to the vision system itself such as the angle of camera's viewing

angle and specification of the camera, the processing unit and the memory capacity. Hardware selection would sometimes append limitations to the software tool or library that can be used to develop the vision algorithm. For the remotely operating system here we are using Personal Area Networks (PAN's) which is Based on the IEEE 802.15.4 standard and this technology is designed by ZigBee Alliance technology which is then mentioned as ZigBee technology.

ZigBee is a technological standard designed for control and sensor networks. Based on the IEEE 802.15.4 Standard Created by the ZigBee Alliance. It Operates in Personal Area Networks (PAN's) and device-to-device networks Connectivity between small packet devices Control of lights, switches, thermostats, appliances, etc. IEEE 802.15.4 standard defining global standards for reliable, cost-effective, low power wireless applications. A consortium of end users and solution providers, primarily responsible for the development of the 802.15.4 standard. Developing applications and network capability utilizing the 802.15.4 packet delivery mechanism.

#### 4. Remote Control

Our aim of this project to provide a robot with vision based live video streaming to see the environment and this is controlled through vision based display and through voice controlled system and it is transmitted through the encryption algorithm and transmitted through the ZigBee wireless technology IEEE 802.15.4. It is provided through series bit of instruction through the voice commands and It is controlled through a series bit of instructions. this will move the robot to right, left, stop, start, etc.,

#### 5. Robot vision

Robot is provided with the wireless camera which is takes images and videos and transmits through live streaming of the video and is transmitted through the RF transmitter and is captured in the receiver section through the RF receiver section and is meant to cover a distance of 150mts and is seen in receiver section through live streaming. And it can detect any objects in the remote area which is to be monitored.

#### 6. Sensing Elements

In this project we are using sensing elements like temperature and humidity and angle displacement for the calculation and knowing angle displacement which is used to detect earth quacks in the remote areas where we are monitoring.

### IV. HARDWARE IMPLEMENTATION

The hardware of the system is mentioned in this paper for the development of the robot which may consist the following terms and blocks.

Mainly it consists of two blocks one is master block which accepts the data and gives commands to the slave section which is operated as per the instructions of the master section.

**Master section** is used to control the slave section of the

robot which is empowered by the power supply and it is serially connected to the PC for monitoring and vision based section. The live video streaming is done and it is seen on the PC screen. And through live streaming the robot is controlled.

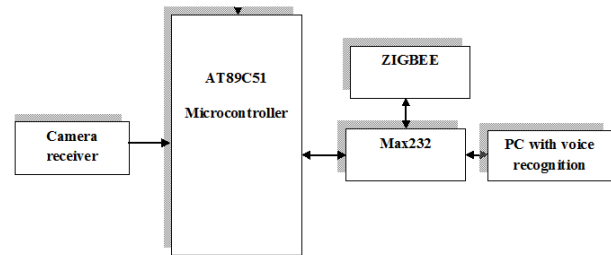

#### Slave section :

Slave section is maintained and is consists of the robot mechanism which is controlled by the master section.

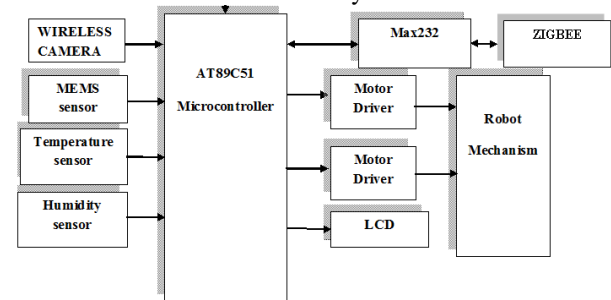

#### Slave section

A Slave robot consists of wire less camera, MEMS sensor, Temperature sensor, Humidity sensor, LCD. All these parts are connected to a AT89C51 Micro controller. A robot mechanism is used to help the slave robot to move. There will be an interface between Micro controller and Robot mechanism.

The slave robot will move according to the instructions given by the master.

### V. CONCLUSION AND FUTURE WORK

The robot is controlled and data is extracted from the area. Remote area where it is data to be extracted and result is processed and the data is encrypted and send to the master section. In future the range of the robots is developed for monitored and it is developed to collect the samples at remote locations. And this are developed to pass through tunnels and in extreme heat conditions.

### REFERENCES

- [1]. Multisensor Fusion-Based Concurrent Environment Mapping and Moving Object Detection for Intelligent Service Robotics Ren C. Luo, Fellow, IEEE, and Chun Chi Lai
- [2]. P. C. Leger, R .G. Deen, R. G. Bonitz, "Remote image analysis for Mars Exploration Rover mobility and manipulation operations", in Proc. IEEE International Conference on Systems, Man and Cybernetics, Hawaii, USA, pp. 917 - 922, Oct. 2005.
- [3]. A. Davids, "Urban search and rescue robots: from tragedy to technology", IEEE Intelligent Systems, Vol. 17 (2), pp. 81 - 83, Mac - April, 2002.
- [4]. B. Day, C. Bethel, R. Murphy, J. Burke, "A depth sensing display for bomb disposal robots", in Proc. of IEEE International Workshop

- on Safety, Security and Rescue Robotics, Sendai, Japan, pp. 146 - 151, Oct. 2008.
- [5]. D. Psarros, V. Papadimitriou, P. Chetaks, V. Spais and K. Hrissagis, "FRC: A low-cost service robot for subsea flexible risers", in *IEEE Proc. of Int. Conf. on Advanced Robotics*, Munich, Germany, pp. 1 – 6, Jun. 2009.
- [6]. Web-based Remote Navigational Robot for Multiclass Human-Robot Interaction Kenny Ju Min Yeoh, Hwee Ling Wong Faculty of Engineering, Multimedia University, Persiaran Multimedia, Cyberjaya, Malaysia
- [7]. D.W. Thiang, "Limited Speech Recognition for Controlling Movement of Mobile Robot Implemented on ATmega162 Microcontroller", in *IEEE Proc of Int. Conf. on Computer and Automation Engineering*, Bangkok, Thailand, pp. 347 - 350, Mac. 2009.
- [8]. H. L. Wong, "Face detection using skin color and eigenface techniques for human-robot interaction", M. Eng. thesis, Fac. of Electrical Eng., UTM, Skudai, Johor, Malaysia, 2005.
- [9]. M. A. -A. Bhuiyan, M. E. Islam, N. Begum, M. Hasanuzzaman, H. L. Chang, H. Ueno, "Vision based gesture recognition for human-robot symbiosis", in *IEEE Proc of Int. Conf. on Computer and Information Technology*, Dhaka, Bangladesh, pp. 1 - 6, Dec. 2007.
- [10]. J. Schlotz, "Theory and evaluation of human-robot interactions", in *Proc. IEEE of the 36th annual Hawaii International Conference on System Science*, Big Island, Hawaii, USA, pp. 125 – 134, Jan. 2003.
- [11]. A. Sekmen, "Human robot interaction methodology", Ph.D. Dissertation, Dept. Electrical & Computer Eng., Vanderbilt Univ., Nashville, Tennessee, USA, 2000.